

Gas Industry Standard

GIS/F10:2021

Specification for

**Ancillary fittings used for the live insertion of gas
mains operating at pressures equal to or less
than 75 mbar**

Cadent
Your Gas Network

Northern
Gas Networks

 **SGN**
Your gas. Our network.

 **WALES&WEST**
UTILITIES

Contents

	Page
Foreword	iii
Mandatory and non-mandatory requirements	iii
Disclaimer	iii
Brief history	iv
1 Scope	1
2 Normative references	1
3 Terms and definitions	1
4 Design requirements	2
4.1 General	2
4.2 Safety	2
4.3 Temperature range	2
4.4 Compatibility	3
4.5 Assembly	3
5 Testing	3
6 Documentation	3
7 Modifications	3
8 Packaging	3
9 Interim seal device (nose cone)	3
9.1 Performance requirements	3
9.2 Performance testing	5
10 Annular sealant delivery system	6
10.1 Sealant delivery system performance requirements	6
10.2 Performance tests – sealant delivery system tests	6
11 Polyethylene gland cartridge	6
11.1 Performance requirements	6
11.2 Performance tests	7
12. Filed Condition Testing	7
13. Marking	8
Annex A (normative) Nose cone assembly test	9
Annex B (normative) Nose cone wear and flow test	11
Annex C (normative) System test	14
Annex D (normative) Sealant delivery system tests	16
Annex E (normative) Gland cartridge system test	18
Annex F (normative) Gland cartridge retention test	20
Annex G (normative) Pipe angle sealant delivery test	22
Annex H (normative) Pipe restriction sealant delivery test	25

Contents (continued)

	Page
Figure A.1 — Nose cone assembly test	10
Figure B.1 — Nose cone wear and flow test	12
Figure B.2 — Set-up for nose cone pressure test	13
Figure D.1 — Sealant delivery system test	17
Figure E.1 — Insertion of polyethylene pipe	19
Figure E.2 — Gland cartridge system test	19
Figure F.1 — Gland cartridge retention test	21
Figure G.1 — Pipe angle sealant delivery test above horizontal	23
Figure G.2 — Pipe angle sealant delivery test below horizontal	24
Figure H.1 — Pipe restriction sealant delivery test	26
Table 1 — Polyethylene and metallic pipe combinations	2
Table 2 — Pipe size by type	4
Table 3 — Metallic pipe outside diameters	6

Foreword

Gas Industry Standards (GIS) are revised, when necessary, by the issue of new editions. Users should ensure that they are in possession of the latest edition. Contractors and other users external to Gas Transporters should direct their requests for copies of a GIS to the department or group responsible for the initial issue of their contract documentation.

Comments and queries regarding the technical content of this document should be directed in the first instance to the contract department of the Gas Transporter responsible for the initial issue of their contract documentation.

This standard calls for the use of procedures that may be injurious to health if adequate precautions are not taken. It refers only to technical suitability and does not absolve the user from legal obligations relating to health and safety at any stage.

Compliance with this engineering document does not confer immunity from prosecution for breach of statutory or other legal obligations.

Mandatory and non-mandatory requirements

For the purposes of a GIS the following auxiliary verbs have the meanings indicated:

- can** indicates a physical possibility;
- may** indicates an option that is not mandatory;
- shall** indicates a GIS requirement;
- should** indicates best practice and is the preferred option. If an alternative method is used then a suitable and sufficient risk assessment needs to be completed to show that the alternative method delivers the same, or better, level of protection.

Disclaimer

This engineering document is provided for use by Gas Transporters and such of their contractors as are obliged by the terms of their contracts to comply with this engineering document. Where this engineering document is used by any other party, it is the responsibility of that party to ensure that the engineering document is correctly applied.

Brief history

First published as T/SP/F10 Editorial update to comply with GRM Edited by BSI in accordance with BS 0-3:1997 Reviewed on behalf of the technical standard forum or Gas National collaboration forum by BSI Edited to take account of additional testing requirements for product development Reviewed and references updated by TSF	February 2003 August 2004 August 2006 September 2013 August 2015 March 2021
--	--

© Energy Networks Association on behalf of Cadent Gas Ltd, Northern Gas Networks, SGN and Wales & West Utilities Ltd.

This Gas Industry Standard is copyright and must not be reproduced in whole or in part by any means without the approval in writing of Energy Networks Association.

1 Scope

This Gas Industry Standard specifies the performance requirements of the following ancillary fittings associated with live insertion of polyethylene pipe into metallic gas mains up to 8 inch diameter operating at pressures equal to or less than 75 mbar:

- a) interim seal device (nose cone);
- b) annular sealant delivery system;
- c) polyethylene pipe gland cartridge.

This document shall be read in conjunction with the manufacturer's/supplier's instructions.

2 Normative references

The following referenced documents are indispensable for the application of this document. For dated references, only the edition cited applies. For undated references, the latest edition of the referenced document (including any amendments) applies.

Formal standards

BS EN 10217-1, Welded steel tubes for pressure purposes. Technical delivery conditions. Non-alloy steel tubes with specified room temperature properties

BS EN 10216-1, Seamless steel tubes for pressure purposes. Technical delivery conditions. Non-alloy steel tubes with specified room temperature properties

BS EN 682, *Elastomeric seals — Materials requirements for seals used in pipes and fittings carrying gas and hydrocarbon fluids.*

BS EN 12117, *Plastics piping systems — Fittings, valves and ancillaries — Determination of gaseous flow rate/pressure drop relationships.*

BS EN ISO/IEC 17025, *General requirements for the competence of testing and calibration laboratories.*

Gas Industry Standards

GIS/LC1, Specification for Leak Repair and annular sealants for metallic gas mains and services up to 7bar.

GIS/PL2-1, *Specification for polyethylene pipes and fittings for natural gas and suitable manufactured gas Part 1 - General & PE compounds for use in PE pipes and fittings.*

3 Terms and definitions

For the purposes of this standard the following terms and definitions apply.

3.1 Interim seal device (nose cone)

Interim seal device is a mechanism for preventing the temporary passage of gas along the annulus formed between an inserted polyethylene pipe and a carrier pipe during and after insertion of the polyethylene pipe. It is designed to prevent the annular sealant from entering the gas main upstream of the insertion and to act as a retaining seal for the annular gap sealant during sealant injection. The nose cone may form a permanent part of the insertion installation.

3.2 Annular gap

Space between the inserted polythene pipe and metallic pipe.

3.3 Annular sealant delivery system

Delivery system designed to fill the annular space between the metallic pipe and the inserted polyethylene pipe with an annular sealant conforming to GIS/LC1.

3.4 Polyethylene pipe gland cartridge

Gland cartridge used between the inserted polyethylene pipe and the metallic carrier during insertion of the polyethylene pipe. The gland cartridge connects to the open end of the metallic main situated in the excavation and forms a circumferential seal around the polyethylene pipe to be inserted.

4 Design requirements

4.1 General

4.1.1 The components shall be free of any defects or irregularities that could affect their function or performance.

4.1.2 The components shall be designed to be used with polyethylene pipe conforming to GIS/PL2-1 and metallic pipe combinations as given in Table 1.

Table 1 — Polyethylene and metallic pipe combinations

Metallic pipe nominal bore in	Polyethylene pipe diameter mm	SDR
3	55	11
4	75 90	11 or 13.6 17.6
6	90 125	17.6 17.6
8	125 140 180	17.6 17.6 17.6

4.2 Safety

The risks from using the ancillary fittings shall be as low as reasonably practicable under all site operating conditions. Suitable and sufficient risk and COSHH (if appropriate) assessments shall be undertaken and agreed by the gas transporter.

4.3 Temperature range

The working temperature range shall be $-5\text{ }^{\circ}\text{C}$ to $+30\text{ }^{\circ}\text{C}$.

Whilst ambient conditions of the air and or carrier pipe in the vicinity of an excavation can be as low as $-5\text{ }^{\circ}\text{C}$, the sealant bulk temperature shall not be allowed to fall below $0\text{ }^{\circ}\text{C}$ at any time.

Annular sealants shall be stored within the temperature range of $+5\text{ }^{\circ}\text{C}$ to $+25\text{ }^{\circ}\text{C}$.

4.4 Compatibility

Manufacturers shall demonstrate the compatibility of their system components with annular gap sealants conforming to GIS/LC1 and approved for use in this application. This shall be demonstrated by meeting the requirements of the full system application test and the field trial for live mains transfer section of GIS/LC1.

4.5 Assembly

Manufacturer/suppliers shall provide instruction on the means of assembly and operation of the system components. If specialist tools are required for assembly or operation of the components then they shall be supplied.

5 Testing

The tests detailed in this standard shall be carried out by the manufacturer and witnessed by the gas transporter or their representative(s) or alternatively carried out by an independent laboratory complying with BS EN ISO/IEC 17025 to demonstrate the practicability of the system and show that the components meet the requirements of this standard.

6 Documentation

Following completion of all performance testing, the manufacturer shall compile a data folder that includes details of all test results and a set of drawings showing all critical information, e.g. dimensions, materials, operating pressures and ambient conditions for which the system components are considered suitable, application and safety instructions. All test results shall be signed by the manufacturer and duly agreed with the gas transporter.

7 Modifications

Should there be a change or alteration to materials, manufacturing or a long break in production, reappraisal of approval status may be required. The contractor shall propose the change or changes for consideration as a variant by the gas transporter who shall require any or all of the approval tests to be repeated where performance is considered to be affected. Only on the approval of the variant by the gas transporter, can the change be implemented.

8 Packaging

The manufacturer shall provide adequate packaging of the products to prevent damage by normal handling and storage. All packaging shall be clearly and indelibly marked with appropriate product information.

9 Interim seal device (nose cone)

9.1 Performance requirements

9.1.1 The nose cone shall accommodate the range of pipe bore tolerances as specified in Table 2. It shall also be able to accommodate the internal bores of joints likely to be encountered in the field (it may be necessary to confirm this by the use of on-site gauging pigs). Under the above conditions, the nose cone shall provide a gas and sealant retention seal as close as reasonably practicable to the parent main, within the last section of the main to be replaced. The nose cone shall be positioned within the distances specified in the approved mains replacement program.

Table 2 — Pipe size by type

Type	Metallic main							
	φ3 in		φ4 in		φ6 in		φ8 in	
	Max. mm	Min. mm	Max. mm	Min. mm	Max. mm	Min. mm	Max. mm	Min. mm
Iron	89.4	72.6	112.7	96.8	169.1	147.1	224.5	197.2
Steel	79.9	75.6	106.7	86.1	157.2	141.7	208.9	189.4

9.1.2 The nose cone shall not become detached from polyethylene pipe under all operations including insertion and injection of annular sealant. If the polyethylene pipe is to be withdrawn before annular sealant injection, the nose cone shall remain attached to the polyethylene pipe. Alternatively the nose cone shall be capable of retrieval from the inserted pipe if so required.

9.1.3 The nose cone shall be able to retain the upstream pressure in the inserted pipe during insertion and static positioning and to withstand maximum mains pressure unaided without support from the polyethylene pipe located in either the gland seal or pusher machine.

9.1.4 The polyethylene pipe shall be centralized in the carrier main by means of the nose cone.

9.1.5 It shall be possible to withdraw the core of the nose cone through the internal weld bead of the butt-fused polyethylene pipe if using 90mm polyethylene and above.

9.1.6 The nose cone shall be sufficiently robust to meet the performance requirements after being inserted through a minimum 13 m length of gas main, having a minimum bore size for each particular size of gas main. The nose cone should be tested to the manufacturer's maximum operating distance if above this length of insertion.

9.1.7 The associated pressure drop of the inserted nose cone shall not unduly affect the gas flow characteristics.

9.1.8 The short term performance (a period of 24 h) of the non-metallic parts of the nose cone shall not be adversely affected by the presence of the following substances that may be present in the main:

- monoethylene glycol (MEG);
- diethylene glycol (DEG);
- light lubricating oil;
- distillate.

No specific test is outlined since it will be sufficient for the manufacturer/supplier to choose the manner in which they demonstrate compliance with the above requirements.

9.2 Performance testing

9.2.1 Nose cone assembly test

9.2.1.1 The nose cone assembly test shall be carried out in accordance with Annex A.

9.2.1.2 The test specimen is acceptable if:

- a) It is possible to fully assemble the devices onto the polyethylene pipe; and
- b) a pressure drop of not more 1 mbar over a 5 min period is measured using approved pressure monitoring equipment.

9.2.2 Nose cone wear and flow rate test

9.2.2.1 The wear and flow rate test shall be carried out in accordance with Annex B.

9.2.2.2 The nose cone is acceptable if the flow rate past it is less than or equal to that shown in Table B.1. Furthermore, the nose cone shall remain in position without any support during the pressure test.

9.2.2.3 After the sealant has cured, the nose cone is acceptable if not more than 20 mm of sealant has passed the front of the nose cone, and that sealant has not flowed back into the bore of the nose cone.

9.2.3 Pressure drop test

9.2.3.1 The pressure drop across the nose cone should be kept to a minimum. The minimum internal bore diameter, d_i , shall be stated by the manufacturer in the technical data file.

The determination of the gaseous flow/pressure drop relationship is required by measuring the air flow rate (in m^3/h) at ambient temperature ($23^\circ\text{C} \pm 2^\circ\text{C}$) corresponding to a pressure drop across the fitting of 0.5 mbar and shall be declared by the supplier. The test method shall be in accordance with BS EN 12117.

9.2.4 System test

9.2.4.1 The system test shall be carried out in accordance with Annex C.

9.2.4.2 The system test is acceptable if the criteria laid out in **9.2.4.3** to **9.2.4.8** are met.

9.2.4.3 During the integrity test in accordance with **C.4.1**, the pressure drop shall not exceed 1 mbar over a 5 min period when pressurized to 350 mbar.

9.2.4.4 During the test in accordance with **C.4.4**, the pressure drop shall not exceed 1 mbar over a 5 min period when pressurized to 150 mbar.

9.2.4.5 The minimum length of annular fill shall be 3m.

9.2.4.6 The presence of the annular sealant shall not cause the nose cone to become detached.

9.2.4.7 The annular sealant shall not flow past the nose cone by more than 20 mm.

9.2.4.8 When the annular gap is subjected to pressure in accordance with **C.4.9**, the pressure drop shall not exceed 1 mbar over a 5 min period when pressurized to 150 mbar.

10 Annular sealant delivery system

10.1 Sealant delivery system performance requirements

10.1.1 The system shall be able to deliver sufficient annular sealant through the delivery tube located within the bore of the inserted polyethylene pipe to ensure that a minimum annular fill length of 3m is achieved. Where the target fill for the system is in excess of 3m, the testing should reflect this distance. The maximum length of the delivery tube shall not exceed 5m more than the inserted PE pipe length. Refer to the manufacturer's instructions for the maximum operating distance.

10.1.2 The system shall be capable of delivering the required amount of sealant to the point of application whilst the sealant is still in a fluid state.

10.1.3 The delivery system shall be easy to apply, clean and maintain.

10.2 Performance tests – sealant delivery system tests

A sealant delivery system test shall be carried out in accordance with Annex D for the minimum and maximum size of nose cone to be qualified. For example, testing the 3 inch and 8 inch nose cone will be deemed to include the 4 and 6 inch nose cones. Selection of nose cone, polyethylene pipe and metallic carrier shall be in accordance with Table 1. Steel pipes shall conform to BS EN 10216-1 or BS EN 10217-1.

Failure will be deemed to have occurred if:

- a) it is not possible to deliver the annular sealant to the injection ports on the nose cone over the maximum specified length of sealant delivery tube;
- b) there is a pressure drop of more than 1 mbar over a 5 min period when the annulus between the nose cone and the metallic carrier pipe is pressurized;

Polyethylene gland cartridge

11.1 Performance requirements

11.1.1 A gland cartridge shall be provided for each size of polyethylene pipe to be inserted. The part of the cartridge that connects to the metallic main shall be capable of accommodating pipe sizes as shown in Table 3.

Table 3 — Metallic pipe outside diameters

Nominal diameter in	Min O/D in (mm)	Max O/D in (mm)
3	3.48 (88.3)	3.92 (99.5)
4	4.47 (113.5)	4.88 (123.9)
6	6.56 (166.5)	7.06 (179.3)
8	8.60 (218.5)	9.22 (234.1)

11.1.2 The gland seal material shall meet the requirements of BS EN 682.

11.1.3 The gland seal shall not restrict the ease with which the polyethylene pipe can be inserted into the metallic main.

11.1.4 It shall be possible to remove the gland seal arrangement without disturbing the inserted polyethylene pipe.

11.1.5 The gland cartridge shall remain attached to the carrier pipe under all operating and pressure conditions.

11.2 Performance tests

11.2.1 Gland cartridge system test

A gland cartridge system test shall be carried out for each size of polyethylene pipe in accordance with Annex E. If butt-welded and/or coiled pipe is to be used, then it shall be necessary to conduct tests for both types of polyethylene pipe. Selection of polyethylene pipe and metallic pipe shall be in accordance with Table 3. Steel pipes shall conform to BS EN 10216-1 or BS EN 10217-1.

Failure will be deemed to have occurred if:

- a) it is not possible to insert the polyethylene pipe over a distance of a minimum 13m or the maximum operating distance of the system. Refer to the manufacturer's instructions for this distance;
- b) the leak past the gland seal after a maximum operating distance traverse is greater than 15 l/min at low pressure (150 mbar) conditions;
- c) the gland seal arrangement becomes detached from the carrier pipe during insertion or mains pressure loading.

11.2.2 Gland cartridge retention test

The gland cartridge retention test shall be carried out in accordance with Annex F.

The attachment of the end seal arrangement will be deemed acceptable if it can withstand the applied pressures for a period of 60 min without detaching from the steel pipe.

12 Field condition testing

12.1 Pipe angle sealant delivery test

The system shall be able to deliver sufficient annular sealant through the delivery tube located within the bore of the inserted polyethylene pipe to ensure that a minimum annular fill length of 3m is achieved. This shall be possible if the operation is being undertaken at an angle above or below horizontal.

12.1.1 An angled system test shall be carried out for each size of polyethylene pipe in accordance with Annex G. Selection of nose cone, polyethylene pipe and metallic carrier shall be in accordance with Table 1. Steel pipes shall conform to BS EN 10216-1 or BS EN 10217-1.

Failure will be deemed to have occurred if:

- a) it is not possible to form a full annular fill behind the nose cone;
- b) there is a pressure drop of more than 1 mbar over a 5 min period when the annulus

between the nose cone and the metallic carrier pipe is pressurized.

12.2 Pipe restriction sealant delivery test

The system shall be able to deliver sufficient annular sealant through the delivery tube located within the bore of the inserted polyethylene pipe to ensure that a minimum annular fill length of 3m is achieved. This shall be possible if the operation is being undertaken with a restriction located behind the installed nose cone.

12.2.1 A pipe restriction system test shall be carried out for each size of polyethylene pipe in accordance with Annex H. Selection of nose cone, polyethylene pipe and metallic carrier shall be in accordance with Table 1. Steel pipes shall conform to BS EN 10216-1 or BS EN 10217-1.

Failure will be deemed to have occurred if:

- a) it is not possible to form a full annular fill behind the nose cone;
- b) there is a pressure drop of more than 1 mbar over a 5 min period when the annulus between the nose cone and the metallic carrier pipe is pressurized.

13 Marking

Products conforming to GIS/F10 shall be permanently marked with the following information:

- a) the number and date of this standard, i.e. GIS/F10:2021 ¹⁾;
- b) the name or trademark of the manufacturer or their appointed agent;
- c) the manufacturer's contact details;
- d) where authorized, the product conformity mark of a third party certification body, e.g. BSI Kitemark.

NOTE Attention is drawn to the advantages of using third party certification of conformance to a standard

¹⁾ Marking GIS/F10:2021 on or in relation to a product represents a manufacturer's declaration of conformity, i.e. a claim by or on behalf of the manufacturer that the product meets the requirements of the standard. The accuracy of the claim is therefore solely the responsibility of the person making the claim. Such a declaration is not to be confused with third party certification of conformity, which may also be desirable.

Annex A (normative)

Nose cone assembly test

A.1 Principle

This test determines that a nose cone and the polyethylene pipe can be assembled together at a range of operating temperatures that will be encountered in hot and cold UK weather conditions.

A.2 Apparatus

A.2.1 *Temperature conditioning equipment*, capable of containing polyethylene pipe and nose cone and maintaining a temperature of $30\text{ °C} \pm 1\text{ °C}$.

A.2.2 *Temperature conditioning equipment*, capable of containing polyethylene pipe and nose cone and maintaining a temperature of $-5\text{ °C} \pm 1\text{ °C}$.

A.2.3 *Nose cone assembly tool*.

A.2.4 *Test end*, capable of sealing the bore of the polyethylene pipe with a connection port capable of accommodating a pressure gauge and an isolation valve.

A.2.5 *A means of pressurising the bore of the polyethylene pipe*, via the test end.

A.2.6 *Pressure monitoring equipment*, capable of measuring in steps of 1 mbar.

A.3 Test sample

A.3.1 Four 0.5 m lengths of polyethylene pipe.

A.3.2 Four nose cones.

A.4 Procedure

A.4.1 Prepare four 0.5 m lengths of polyethylene pipe. Condition two lengths of pipe and two nose cones at -5 °C and two lengths of pipe and two nose cones at 30 °C for not less than 24h.

A.4.2 Assemble the devices on to the polyethylene pipe in accordance with the manufacturer's instructions. A nose cone at -5 °C shall be assembled to a piece of polyethylene pipe at 30 °C , and a nose cone at 30 °C assembled to a piece of polyethylene pipe at -5 °C . A nose cone at -5 °C shall be assembled to a piece of polyethylene pipe at -5 °C , and a nose cone at 30 °C assembled to a piece of polyethylene pipe at 30 °C .

A.4.3 Subject the polyethylene pipe and devices to a static pneumatic pressure test of 150 mbar for 5 min in accordance with Figure A.1.

A.5 Expression of results

Record and report the following.

- a) Can the nose cone be fully assembled onto the polyethylene pipe?
- b) The pressure drop over a 5 min period.

A.6 Test report

The test report shall contain the following information:

- a) a reference to this method;
- b) the temperatures at which the samples were assembled measured in °C;
- c) the extent to which each sample can be assembled;
- d) the pressure drop on each sample measured in mbar.

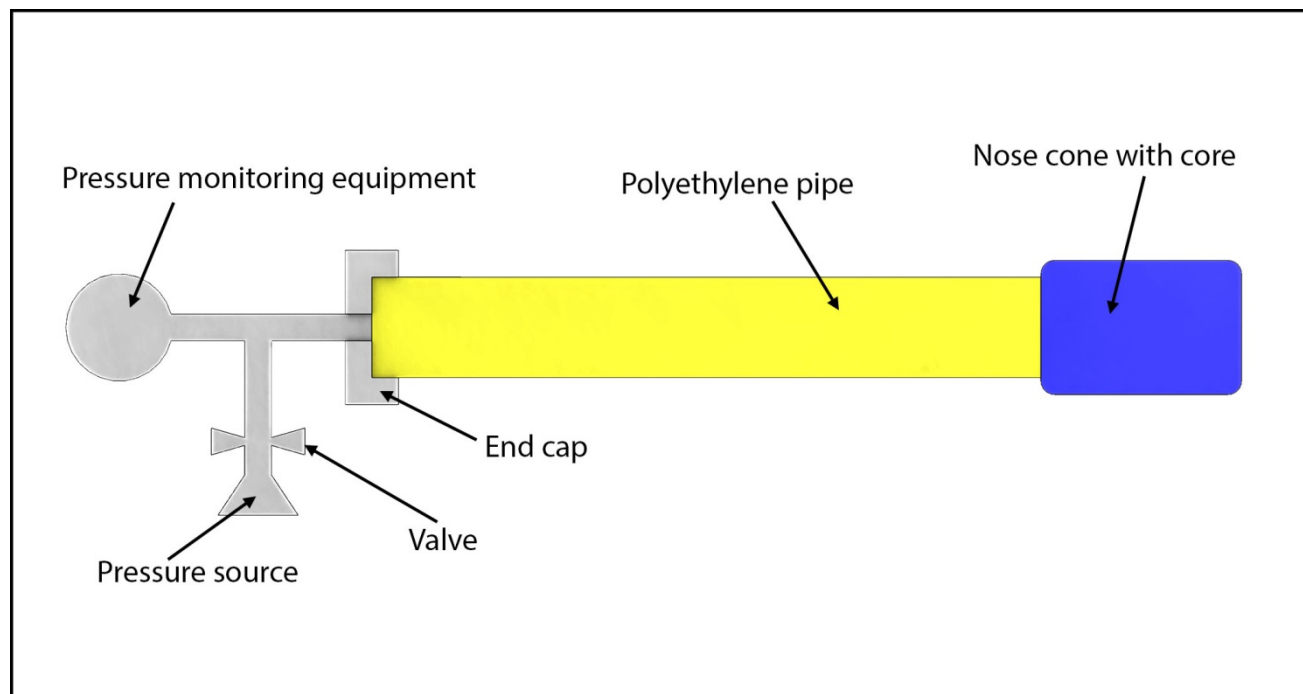

Figure A.1 — Nose cone assembly test

Annex B (normative)

Nose cone wear and flow test

a.1 Principle

This test determines that the nose cone will have sufficient resistance to frictional wear when inserted along a representative length of metallic pipe containing a protrusion and will be capable of:

- a) containing live gas at low pressure conditions;
- b) preventing an unacceptable quantity of sealant from passing between the nose cone and the metallic pipe into which it has been inserted.

a.2 Apparatus

B.2.1 *Metallic pipe.*

B.2.2 *1 inch BSP plug.*

B.2.3 *Supply of air, at a pressure of 150 mbar.*

B.2.4 *Pressure monitoring equipment, capable of measuring in steps of 1 mbar.*

B.2.5 *Equipment capable of measuring air flow, in steps of 1 l/min.*

B.2.6 *Polyethylene pipe pushing machine (optional if required).*

B.3 Procedure

B.3.1 Prepare a section of metallic test pipe. It is not necessary to have a full representative length of pipe since it is acceptable to pass the nose cone through a single length of pipe several times to simulate the full length. At least one section of pipe needs to contain a protrusion as shown in Figure B.1. The simulated mains length shall be a minimum of 13m or the maximum operating distance of the system. Refer to the manufacturer's instructions for this distance.

The pipe shall have the minimum bore for each size of pipe. Dimensions are shown in Table 2.

B.3.2 Assemble the nose cone onto a section of polyethylene pipe, minimum length 4 m, with the minimum diameter as given in Table 1, in accordance with the manufacturer's instructions.

B.3.3 Insert the polyethylene pipe and nose cone through the simulated distance of the test pipe using a pushing machine if necessary. Ensure that the nose cone only travels in the one direction through the test pipe.

B.3.4 Then insert the nose cone into a 3 m length of metallic pipe having the maximum bore. Dimensions are shown in Table 2.

B.3.5 Connect an air supply to the steel pipe as illustrated in Figure B.2 such that the steel pipe has a pressure of 150 mbar applied to it.

B.3.6 Inject the sealant into the annular space through the nose cone and allow to cure. Examine the leading edge of the nose cone upstream of the insertion for traces of sealant.

B.4 Expression of results

B.4.1 The let by flow rate past the nose cone shall be expressed in terms of litres per minute. The maximum allowable flow rate is 15l/min.

B.4.2 The amount of sealant that passes past the nose cone shall be measured in millimetres.

B.5 Test report

The test report shall include the following information:

- a reference to this method;
- the results of the flow rate test as a number with one decimal place;
- the results of the sealant passing test expressed in terms of an integer number;
- any observation as to the extent that sealant has entered back into the bore of the nose cone.

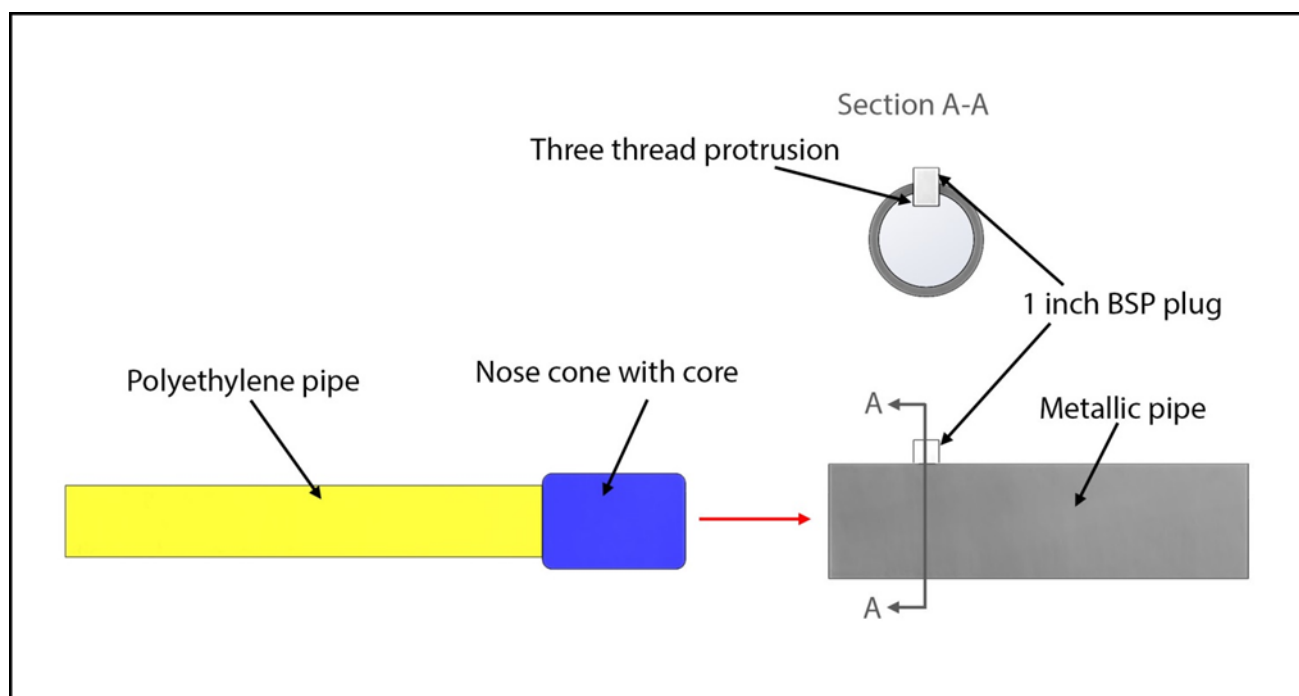

Figure B.1 — Nose cone wear and flow test

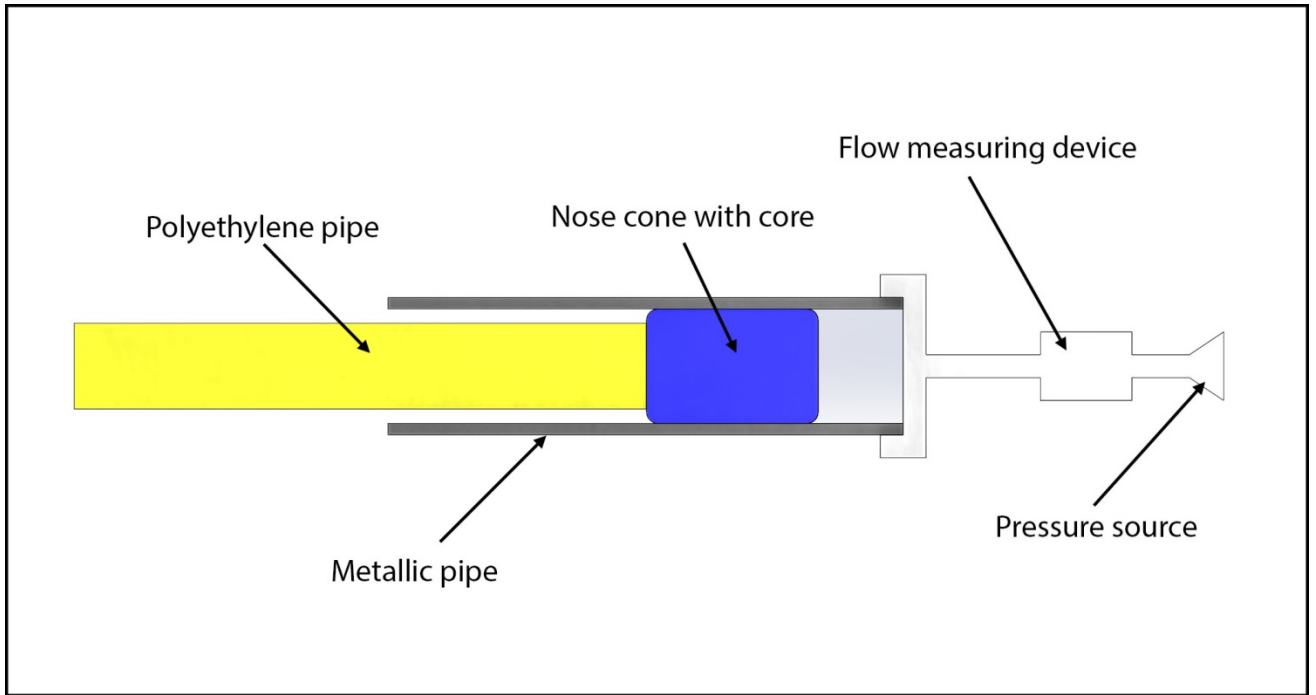

Figure B.2 — Set-up for nose cone pressure test

Annex C (normative)

System test

C.1 Principle

This test determines that the nose cone will be able to function as desired when deployed under field type conditions. In particular, the test is designed to demonstrate that the nose cone can be inserted into a metallic pipe to the maximum operating distance of the system. Refer to the manufacturer's instructions for this distance. This shall be able to retain the annular sealant when it is injected into the system. The system also demonstrates that the nose cone core can be retracted after the annular sealant has cured.

C.2 Apparatus

C.2.1 *Launch equipment.*

C.2.2 *Pressure source, at 150 mbar.*

C.2.3 *Metallic pipe.*

C.2.4 *Pressure monitoring equipment, capable of measuring in steps of 1mbar.*

C.2.5 *Polyethylene pipe pushing machine (optional if required)*

C.3 Test sample

For each main diameter to be qualified, it will be necessary to test each size of nose cone and corresponding size of polyethylene in conjunction with the correct size of metallic pipe.

C.4 Procedure

C.4.1 Prepare a length of polyethylene pipe. In the case of 90mm and above polyethylene pipe, this may be by butt fusion. If butt fusion is used, then perform an integrity test on pipe and joints at a pressure of 350 mbar for 5 min. Ensure the pressure drop does not exceed 1 mbar over 5 min.

C.4.2 Prepare a section of test main to be inserted. The length of the main should be sufficient to accommodate the maximum operating distance insertion

C.4.3 Insert the polyethylene pipe through the polyethylene gland cartridge and launch equipment and attach the nose cone and sealant delivery tube. Pressure test nose cone arrangement and polyethylene bore to 150 mbar. Ensure the pressure drop does not exceed 1 mbar over 5 min. This is a nose cone integrity test.

C.4.4 Assemble the launch assembly onto the metallic pipe. Insert the nose cone and polyethylene pipe to the maximum operating distance insertion in accordance with the manufacturer's instructions

C.4.5 Withdraw the polyethylene pipe and nose cone to ensure that the nose cone section can be retracted. If the nose cone remains attached, but is damaged, then it will be necessary to replace the noses cone with a new one. If the nose cone becomes detached in the pipe it will be necessary to retrieve it by suitable means. It will then be necessary to recommence the procedure from **C.4.2** through to **C.4.5** and then onto step **C.4.7**. If it is not possible to retrieve the nose cone then the system test requirements will not have been met

C.4.6 Connect the sealant delivery system and inject sealant. Ensure the quantity of sealant required is in accordance with manufacturer's instructions.

C.4.7 When the sealant has cured sufficiently, in accordance with the manufacturer's instructions, remove the launch assembly, retrieve the nose cone core and squeeze off the polyethylene pipe. Determine the length of the annular fill. Ensure the annular sealant reaches minimum flow back length in accordance with the manufacturer's instructions. In any event ensure that this length is greater than 3 m

C.4.8 Allow the sealant to cure for 24 h and remove the nose cone section from the main and conduct a pressure drop test on annular fill of the inserted main. Ensure the pressure drop does not exceed 1 mbar in 5 min at a pressure of 150 mbar

C.5 Expression of results

Record and report the following.

- a) The results of any pressure drop in mbar during the integrity test in accordance with **C.4.1**.
- b) After assembling the nose cone and sealant delivery tube, record any pressure drop in mbar in accordance with **C.4.4**.
- c) Has the annular sealant gone past the nose cone?
- d) Has the nose cone become detached by the presence of the annular sealant?
- e) The minimum length of fill of annular sealant.
- f) When the annular gap is subjected to pressure in accordance with **C.4.9**, record any pressure drop over a 5 min period.

C.6 Test report

The test report shall include the following information:

- a) a reference to this method;
- b) the results as outlined in Clause **C.5**;
- c) any additional factors which may affect the results.

Annex D (normative)

Sealant delivery system tests

D.1 Principle

The object of this test is to confirm that the system is capable of delivering an adequate quantity of sealant to the correct location.

D.2 Apparatus

D.2.1 *Temperature conditioning equipment*, capable of maintaining a temperature of $25\text{ °C} \pm 1\text{ °C}$.

D.2.2 *Temperature conditioning equipment*, capable of maintaining a temperature of $+5\text{ °C} \pm 1\text{ °C}$.

D.2.3 *Temperature conditioning equipment*, capable of maintaining a temperature of $-5\text{ °C} \pm 1\text{ °C}$.

D.2.4 *Nose cone assembly tool*.

D.2.5 *Means of pressurising the annular gap*, at a pressure of 150 mbar.

D.2.6 *Pressure monitoring equipment*, capable of measuring in steps of 1 mbar.

D.2.7 *Rule*.

D.3 Test sample

D.3.1 Two lengths of steel pipe 2.5 m long.

D.3.2 Two lengths of polyethylene pipe 3 m long.

D.3.3 Two nose cones.

D.4 Procedure

D.4.1 Prepare two lengths of steel pipe in accordance with BS EN 10216-1:2003 or BS EN 10217-1:2002 for each size of nose cone to be tested (see Table 1). Degrease all internal pipe work. Prepare each length of steel pipe to be 2.5 m long. Provide two lengths of polyethylene pipe 3 m long for each nose cone to be tested in accordance with Table 1.

D.4.2 Condition a length of steel pipe and polyethylene pipe at -5 °C and a length of steel pipe and polyethylene pipe at 25 °C for a period of 24 h. Condition a sample of annular sealant, a nose cone and a length of sealant delivery tube at 5 °C , and a sample of annular sealant, a nose cone and a length of sealant delivery tube at 25 °C .

D.4.3 For the low temperature test, assemble the low temperature nose cone and sealant delivery tube to the low temperature polyethylene pipe in accordance with the manufacturer's instructions, as shown in Figure D.1. Insert nose cone and polyethylene pipe into low temperature steel pipe as shown in Figure D.1. Inject the high temperature annular sealant and allow to cure in accordance with the manufacturer's instructions. Remove nose cone core in accordance with the manufacturer's instruction. Leave sample for a further 24 h before undertaking any tests.

D.4.4 For the high temperature test, assemble the high temperature nose cone and sealant delivery tube to the high temperature polyethylene pipe in accordance with the manufacturers instructions, as shown in Figure D.1. Insert nose cone and polyethylene pipe into high

temperature steel pipe as shown in Figure D.1. Inject the low temperature annular sealant and allow to cure in accordance with the manufacturer's instructions. Remove nose cone core in accordance with the manufacturer's instruction. Leave sample for a further 24 h before undertaking any tests.

D.5 Expression of results

Record and report the following for each sample.

- a) The temperature at which sample was assembled in °C.
- b) The temperature of the sealant prior to injection in °C.
- c) That sealant has been delivered through all the ports in the nose cone.
- d) The extent to which annular sealant is protruding back into the bore of the nose cone in millimetres.
- e) The pressure drop across the annular sealant measured in mbar.

D.6 Test report

The test report shall include the following information:

- a) a reference to this method;
- b) the results measured in accordance with **D.5** for each sample;
- c) any additional factors which may have affected the results.

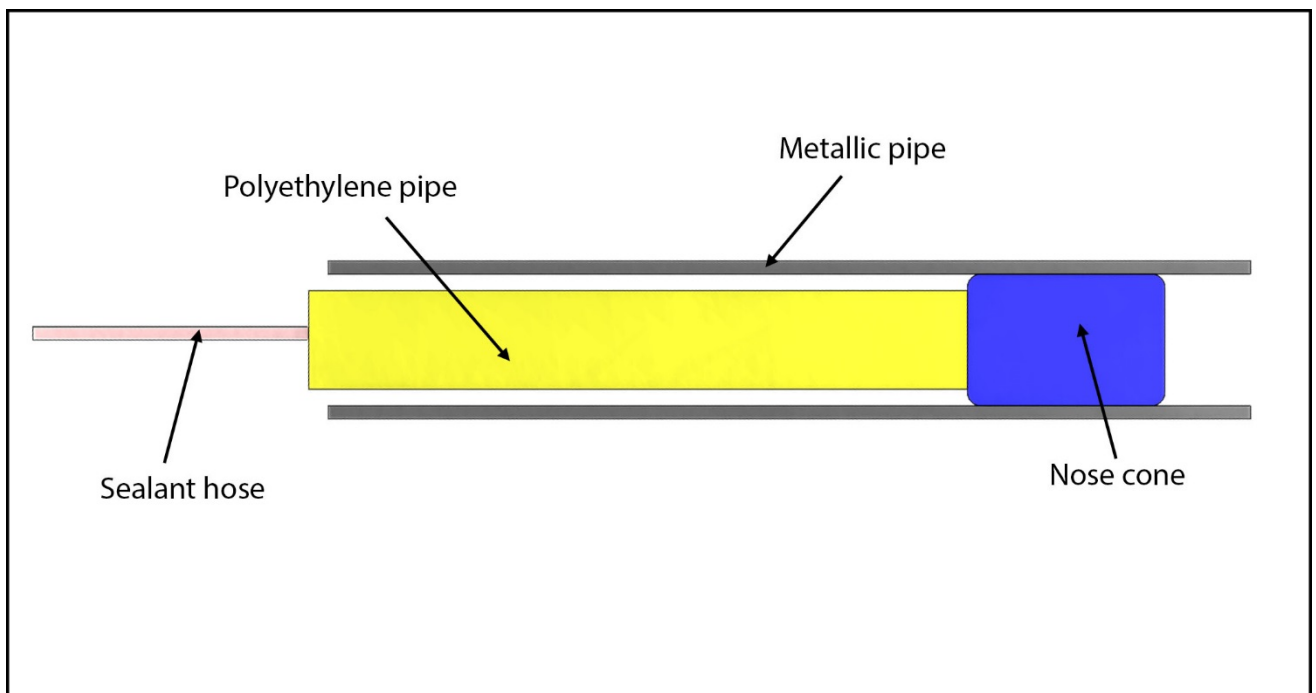

Figure D.1 — Sealant delivery system test

Annex E (normative)

Gland cartridge system test

E.1 Principle

This test determines that the polyethylene pipe can be inserted through the gland seal; that the gland seal will contain pressure and that the gland seal will remain attached to the steel pipe during the operation.

E.2 Apparatus

E.2.1 *Means of pressurising the annular gap*, at a pressure of 150 mbar.

E.2.2 *Pressure monitoring equipment*, capable of measuring in steps of 1 mbar.

E.3 Test sample

E.3.1 Length of steel pipe, 2 m long.

E.3.2 Length of polyethylene pipe a minimum 15m long or 2m longer than maximum operating distance if above this length of insertion.

E.3.3 Gland seal.

E.4 Procedure

E.4.1 Prepare a 2 m length of steel pipe conforming to BS EN 10216-1 or BS EN 10217-1 for each size of polyethylene pipe to be inserted (see Table 1). Provide one length of polyethylene for each gland cartridge to be tested in accordance with Table 1.

E.4.2 Set up the gland cartridge onto the steel pipe and insert the polyethylene pipe as shown in Figure E.1. Ensure that that the maximum operating distance of polyethylene is inserted through the gland cartridge.

E.4.3 Cut off excess polyethylene pipe and fit test end cap as shown in Figure E.2. Ensure that the downstream end of the polyethylene pipe is sealed against gas flow. Pressure test the gland cartridge to a pressure of 150 mbar and monitor the gas flow (maximum acceptable flow rate of 15 litres per minute).

E.5 Expression of results

Record and report the following.

- a) The length of polyethylene pipe that has been inserted through the gland seal in metres.
- b) The air leakage rate past the gland seal measured in litres per minute.
- c) Has the gland seal remained attached to the steel pipe throughout the operation?

E.6 Test report

The test report shall include the following information:

- a) a reference to this method;
- b) the results of the measurements in accordance with Clause **E.5**;
- c) any additional factors which may have affected the results.

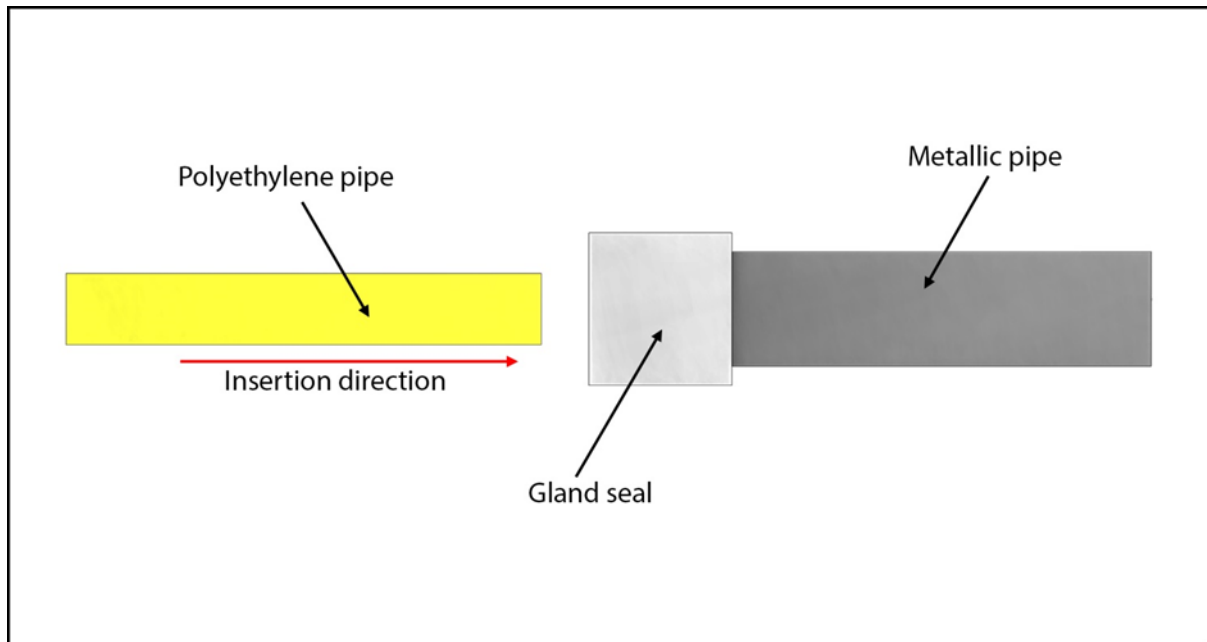

Figure E.1 — Insertion of polyethylene pipe

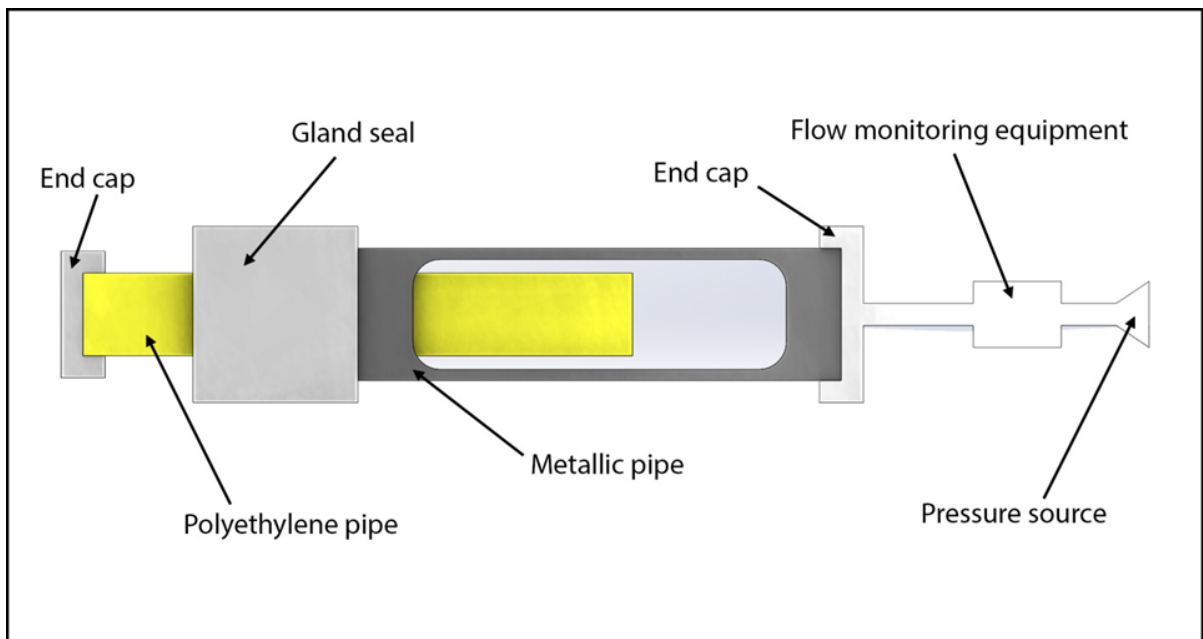

Figure E.2 — Gland cartridge system test

Annex F (normative)

Gland cartridge retention test

F.1 Principle

The purpose of this test is to demonstrate that the attachment of the gland seal arrangement to the metal carrier pipe will be able to contain the pressure loads under low pressure operating conditions. In principle, the attachment shall be able to contain the annular pressure existing between the polyethylene pipe and metal carrier pipe.

F.2 Apparatus

F.2.1 *Pressure source*, at 300 mbar.

F.2.2 *Blanking flange*.

F.2.3 *Means of monitoring pressure*.

F.2.4 *Restraining straps*.

F.3 Test sample

F.3.1 Steel pipe.

F.3.2 Gland cartridge

F.4 Procedure

F.4.1 For each size of polyethylene pipe to be qualified, attach the gland cartridge to the metal carrier pipe as shown in Figure F.1. It may be necessary to add a safety restraint to ensure that if the end cap or gland housing become detached under pressure, a safety hazard will not be caused.

F.4.2 Pressurise the arrangement to 300 mbar and hold for 60 min.

F.5 Expression of results

Record and report the following.

- a) The test pressure in mbar.
- b) The test time in hours.
- c) Has the gland seal remained attached to the steel pipe?

F.6 Test report

The test report shall include the following information:

- a) a reference to this method;
- b) the results in accordance with Clause **F.5**.

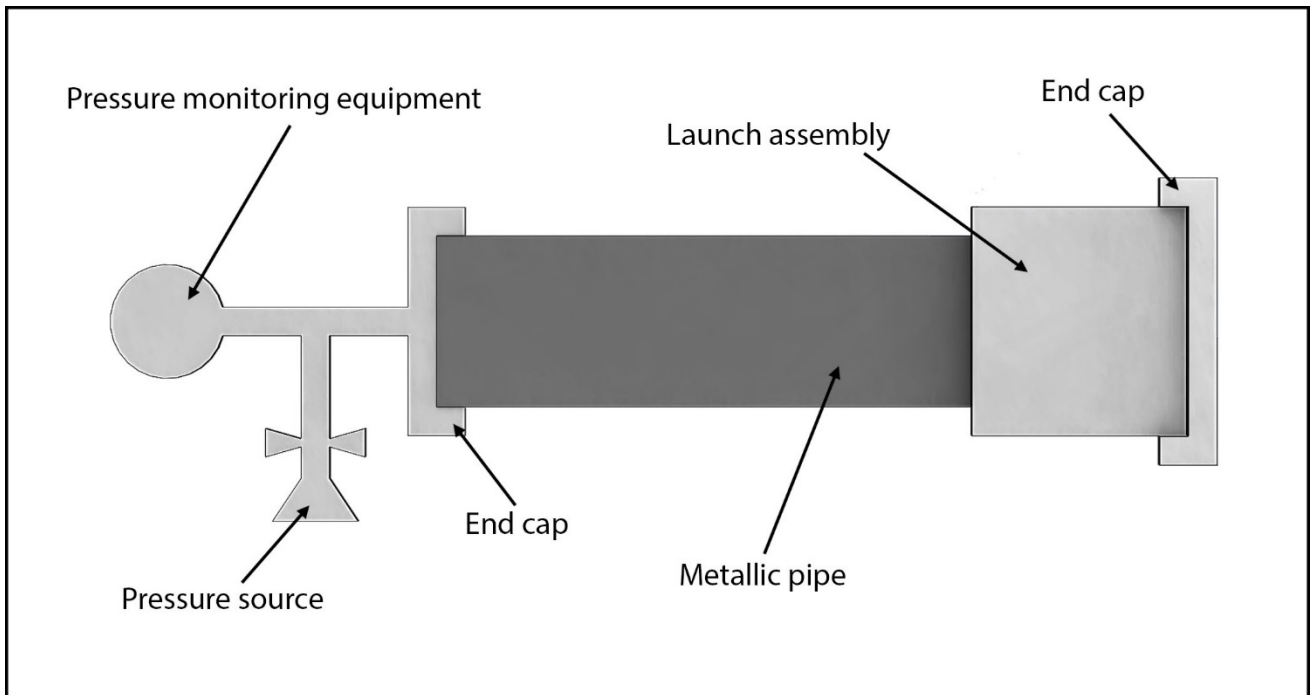

Figure F.1 — Gland cartridge retention test

Annex G (normative)

Pipe angle sealant delivery test

G.1 Principle

This test determines that the nose cone and sealant delivery system will function as desired when deployed under field type conditions. In particular, the test is designed to ensure an annular fill of a minimum 3m can be achieved even if the angle of the pipe is at 10 degrees above or below horizontal. Each size of system will need to be verified to ensure they pass the angle test.

G.2 Apparatus

G.2.1 *Sealant injection machine.*

G.2.2 *Nose cone assembly tool.*

G.2.3 *Supply of air, at a pressure of 150 mbar.*

G.2.4 *Pressure monitoring equipment, capable of measuring in steps of 1 mbar.*

G.2.5 *Polyethylene pipe pushing machine (optional if required)*

G.2.6 Measuring Calipers

G.3 Test sample

G.3.1 Two 6m lengths of metallic pipe.

G.3.2 Two 6m lengths polyethylene pipe.

G.3.3 Two nose cones.

G.3.4 Sealant.

G.4 Procedure

G.4.1 Assemble the nose cones and sealant hoses onto the sections of polyethylene pipe, in accordance with the manufacturer's instructions.

G.4.2 Insert the two polyethylene pipes and nose cones through 5.5 m of the test metallic pipe using a pushing machine if necessary.

G.4.3 For one test sample, raise the nose cone end of the pipe to 10 degrees above horizontal.

G.4.4 For the second test sample lower the nose cone end of the pipe to 10 degrees below horizontal.

G.4.5 Inject the sealant into the annular space through the nose cones and allow to cure in accordance with the manufacturer's instructions Examine the leading edge of the nose cone upstream of the insertion for traces of sealant.

G.4.6 Remove nose cone core in accordance with the manufacturer's instructions. Leave sample for a further 24 h before undertaking any tests.

G.5 Expression of results

Record and report the following for each sample.

- a) That sealant has been delivered through the ports in the nose cone.
- b) The amount of sealant that passes past the nose cone, measured in millimetres.
- c) The annular fill is complete behind the nose cone for a minimum 3 metres.
- d) The pressure drop across the annular sealant measured in mbar.

G.5 Test report

The test report shall include the following information:

- 12.2.1.1 a reference to this method;
- 12.2.1.2 any observation as to the extent that sealant has entered back into the bore of the nose cone.
- 12.2.1.3 the results measured in accordance with **G.5** for each sample;
- 12.2.1.4 any additional factors which may have affected the results.

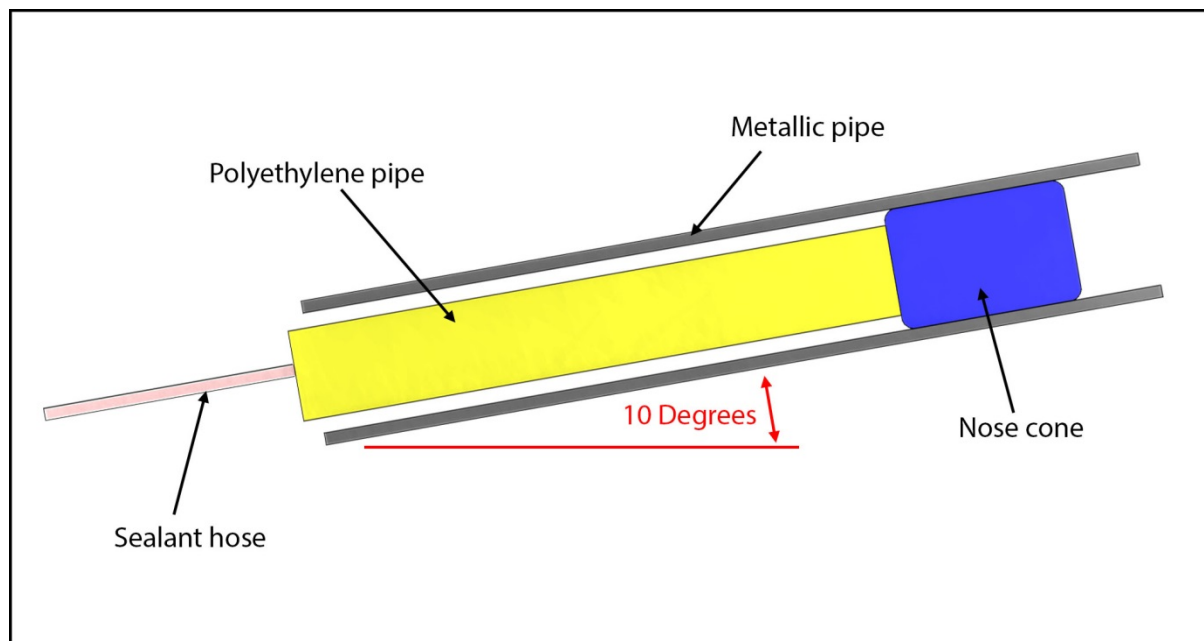

Figure G.1 — Pipe angle sealant delivery test above horizontal

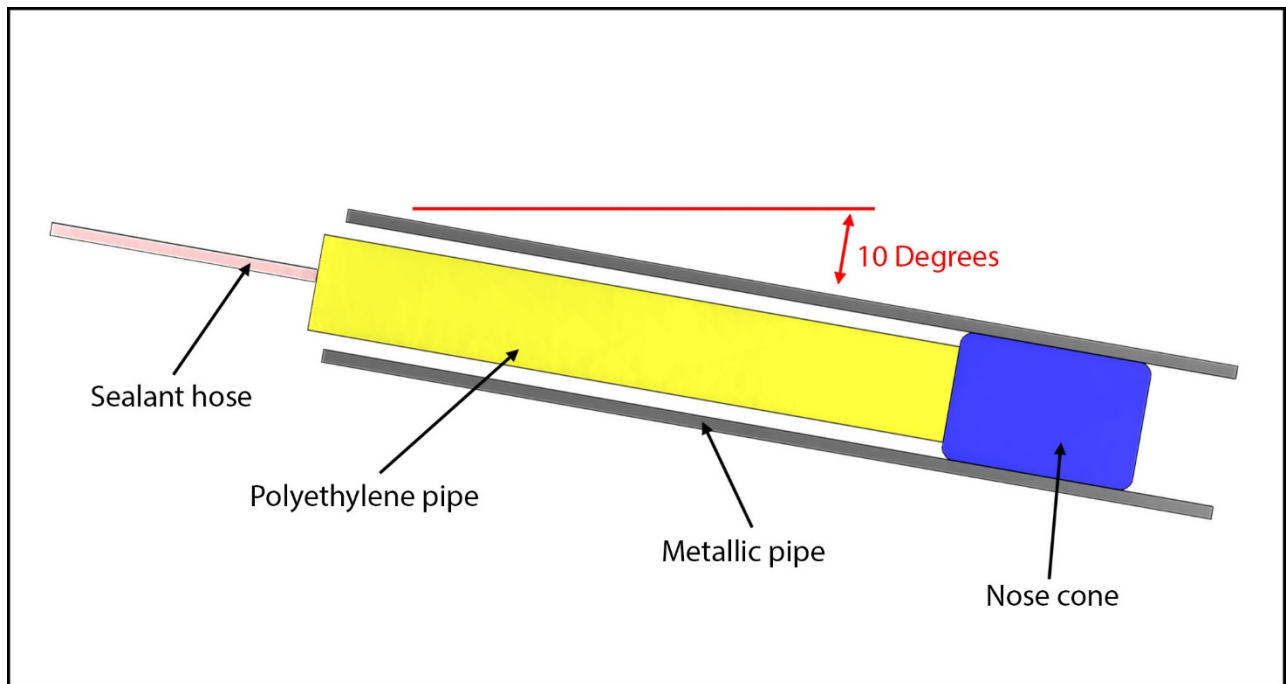

Figure G.2 — Pipe angle sealant delivery test below horizontal

Annex H (normative)**Pipe restriction sealant delivery test****H.1 Principle**

This test determines that the nose cone and sealant delivery system will function as desired when deployed under field type conditions. In particular, the test is designed to ensure an annular fill of a minimum 3m can be achieved even if there is an in pipe restriction behind the nose cone. Each size of system will need to be verified to ensure they pass restriction test.

H.2 Apparatus

H.2.1 *Sealant injection machine.*

H.2.2 *Nose cone assembly tool.*

H.2.3 *Supply of air, at a pressure of 150 mbar.*

H.2.4 *Pressure monitoring equipment, capable of measuring in steps of 1 mbar.*

H.2.5 *Polyethylene pipe pushing machine (optional if required)*

H.2.6 Measuring Calipers

H.3 Test sample

H.3.1 Two 1.5m lengths of metallic pipe.

H.3.2 Pipe restriction

H.3.3 6m length polyethylene pipe.

H.3.4 Nose cone.

H.3.5 Sealant.

I.4 Procedure

H.4.1 Assemble the nose cone and sealant hose onto a section of polyethylene pipe, in accordance with the manufacturer's instructions.

H.4.2 Insert the polyethylene pipe and nose cone into a piece of metallic pipe using a pushing machine if necessary.

H.4.3 Fit a pipe restriction 1 metre behind the nose cone. The restriction should be a minimum 150mm long and no more than 15mm bigger in diameter than the Polyethylene pipe diameter (e.g for 75mm PE the restriction would have a 90mm bore). Attach the second 1.5m metallic pipe to the pipe restriction.

H.4.4 Inject the sealant into the annular space through the nose cone and allow to cure in accordance with the manufacturer's instructions Examine the leading edge of the nose cone upstream of the insertion for traces of sealant.

H.4.5 Remove nose cone core in accordance with the manufacturer's instructions. Leave sample for a further 24 h before undertaking any tests.

H.5 Expression of results

Record and report the following for each sample.

- That sealant has been delivered through the ports in the nose cone.
- The amount of sealant that passes past the nose cone, measured in millimetres.
- The annular fill is complete behind the nose cone for a minimum 3 metres.
- The pressure drop across the annular sealant measured in mbar.

H.6 Test report

The test report shall include the following information:

- a reference to this method;
- any observation as to the extent that sealant has entered back into the bore of the nose cone.
- the results measured in accordance with **H.5** for each sample;
- any additional factors which may have affected the results.

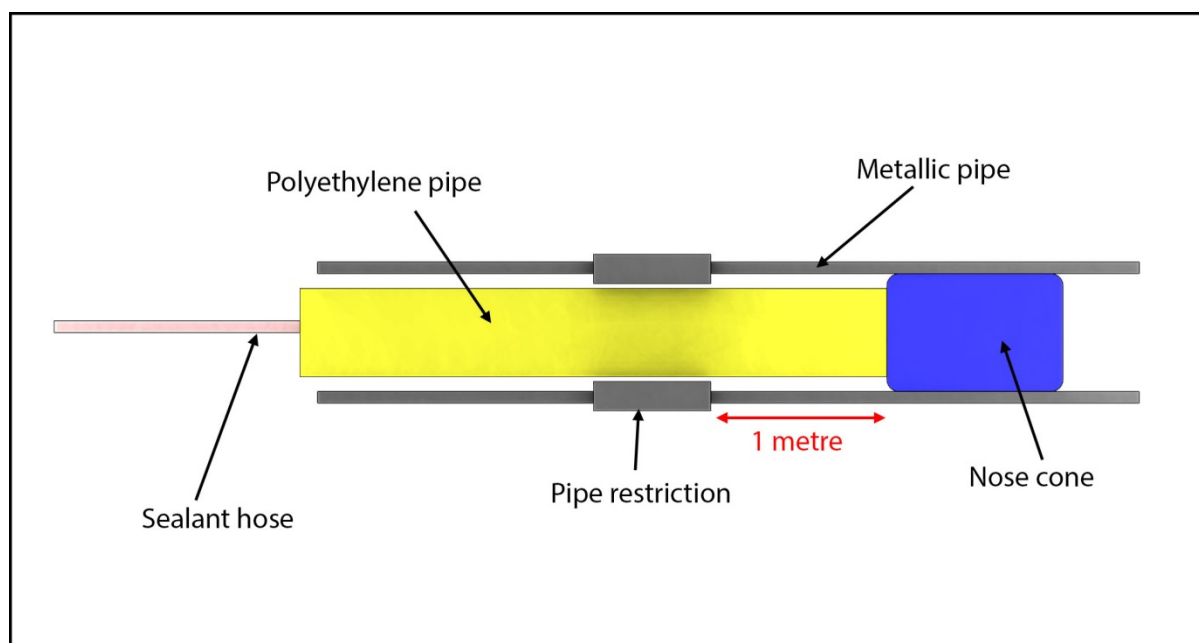

Figure H.1 - Pipe restriction sealant delivery test